



# SEA BOATS

MARINE BROKERS WITH A GLOBAL APPROACH

AUSTRALIA - BULGARIA - INDIA - INDONESIA - ITALY - MALAYSIA - NEW ZEALAND - PANAMA - PHILIPPINES - SINGAPORE - SPAIN - UK - USA - VENEZUELA - VIETNAM

[sales@seaboats.net](mailto:sales@seaboats.net)

[www.seaboats.net](http://www.seaboats.net)

## NEW BUILD - Centurion 40 Mooring Workboat.



### Listing ID - 2065

**Description** NEW BUILD - Centurion 40 Mooring Workboat

**Date** Built to Order

**Launched**

**Length** 12m (30ft 4in)

**Beam** 3.5m (11ft 5in)

**Location** ex factory, Singapore

**Broker** Geoff Fraser or Richard Pierrepont

The centurion 40 an extremely versatile and reliable workboat, it can be served as a mooring boat and an oil spill response boat at the same time. This workboat has an in built chemical tank for oil spill response and a bollard pull of up till 2000kg. It can also be configured into a passenger boat with a spacious cabin for 12 passengers and 2 crews.

Hull Length: 12.00m (40ft)

Beam: 3.50m

Depth: 1.9m

Draft: Approx. 1.2m unladen

Hull Weight: 7500kg unladen weight

Power by: Single ISUZU UM6GB1TCX (281HP) Marine Diesel Engine

Fuel Tank Capacity: Built-in 500litre Fuel Tank

Material: Marine Grade Aluminium Alloy (5083H321)

Hull bottom thickness: 6mm

Hull side thickness: 6mm

Deck: Aluminium Alloy Checker Plate (Thickness:4mm)

Bollard Pull: 2 Tons

Class Type: Not build to Class Survey

## **Standard Configuration**

- 1) Marine Grade Aluminium Alloy Construction with 3 or 4 Water Tight Bulkheads
- 2) Multiple Transverse & Longitudinal Frame Reinforcement Structures under deck
- 3) Fully welded keel and chines with additional SKEG
- 4) Aluminium Alloy Plate Deck - fully welded to hull side plate
- 5) Self draining cockpit with twin drainage hole towards stern
- 6) 4 Nos Alloy Open Type Fairlead, 6 Nos Alloy Cleats welded onto gunwhale at suitable locations with double plate reinforcement.
- 7) Aluminium Alloy gunwhale section (See drawing)
- 8) 500litres Aluminium Alloy Fuel Tank with baffles and pressure tested and bolted down in underfloor chamber with sight glass.
- 9) 1 No Filling Air Vent and 1 No Lockable Fuel Filling Cap
- 10) Collapsible Mast Mounted on top of Wheelhouse
- 11) Forward Bow Platform about 1m length with Centre Boarding Rails using 1 ¼" diameter Alloy tubing gully welded to deck
- 12) Side Holding Handrails using 1 ¼" diameter alloy tubing fully welded to gunwhale
- 13) Forward 3 sided wheelhouse with Steering Console with Hydraulic Steering System and connected to rudder. Height from main deck to top of wheelhouse less than 1.6m.
- 14) Hardened Glass Front Windshield with Aluminium Anodised Frame with 2 others front push out opening. Side windows to be drop down type for ventilation purpose.
- 15) Single Clearview Circular Windshield (DIA 12") Wiper on Driver Side Windshield
- 16) 2 Nos Cushion Type Seating for Coxwain and Deckhand at Driving Console with additional seatings for 6 crews with storage boxes under.
- 17) Boat is painted with Jotun Marine PU paint system. All compartment painted except fuel tank.
- 18) Anchor locker and hatch under bow platform
- 19) 4 Nos of Lifting Eye welded onto deck and frame at floor level
- 20) Aluminium Towing Post with Strut Support and structural reinforcement under deck
- 21) Water Tight Aluminium Engine Room Cover
- 22) 2 Nos Side Engine Compartment Ventilation on Ports and Starboard Sides.
- 23) Heavy Duty 6" D Shape Rubber Fender bolted onto gunwhale all round.
- 24) Overhead Rope Guard on Port and Starboard Sides of Wheelhouse
- 25) 2,000Litres SS 316L Chemical Storage Tank with Sight Glass installed underfloor. Forward mounting for spray pump, side arms bracket on port and Starboard Sides Suitable for mounting dispersant Spray Arms, Separate Sea Check with Flange to Dispersant Pump Suction Line (Pump, Dispersant Spray Arm, Motors and Accessories for the discharge of the dispersant is not included in this scope of supply)
- 26) Sufficient Zinc Anodes to be installed at hull bottom near Rudder and Main Propeller Shaft

## **Accessories Fitted & Supplied**

- 1) 24V Electric Horn mounted at Driving Console
- 2) 6 Way Toggle Type Gang Switches (24 Volt) at Driving Console
- 3) One set of Navigation Lights consisting of 1 No of All Round White Light, Combination Port and Starboard Sidelamps, Stern Light with Light Mast to be mounted atop cabin
- 4) 4 Nos. 12V Lead Acid Battery to be connected in series for 2 banks of 24V with Plastic Battery Box mounted inside Engine Compartment
- 5) Manually operated search light mounted above helmsman on top of wheelhouse
- 6) Rudder Position Indicator
- 7) 2 Nos 50w Floodlight installed at Deck Area for night work
- 8) 1 No. Loud Hailer Installed
- 9) 1 No. AIS Class B / Transponder installed
- 10) 1 No. Whale Manual Bilge Pump installed on Deck with Piping and Valve Manifold installed with Piping to all

water tight compartment

11) 10inch diameter Magnetic Compass

### Engine Room

- 1) ISUZU UM6BG1TCX (281Hp) Marine Diesel Engine, with NICO MGN40E Marine Gear
- 2) 4 Nos Resilient Mountings for Engine
- 3) Stainless Steel 316L Propeller Shafting
- 4) PPS Shaft Seal System installed
- 5) 1 No. 4 Bladed Bronze Propeller
- 6) 1 No. Aluminium Alloy Seachest Constructed with Clearview Top Cover installed / welded onto hull bottom with suitable piping and shut off valve with piping to main engine water intake. Filter Netting to be 1.6mm DIA holes
- 7) 1 No. Seawater Intake Bronze Seawater Scoop installed at Hull Bottom for dispersant pump intake.
- 8) 2 No. Battery On-Off Switch
- 9) 1 No. Fuel Emergency Shut Off Cock with Fuel Hose
- 10) 1 No. Duplex Fuel-water Separator with chargeover cock installed.
- 11) 5 Nos 1200GPH Rule Bilge Pump with Automatic Float Switch Installed (1PC inside every water tight bulkhead compartment) with high water level alarm
- 12) 1 No stainless-steel rudder (15% Larger) with Rudder Stock and Packing Gland
- 13) 1 No. Connection Hose for Oil Change

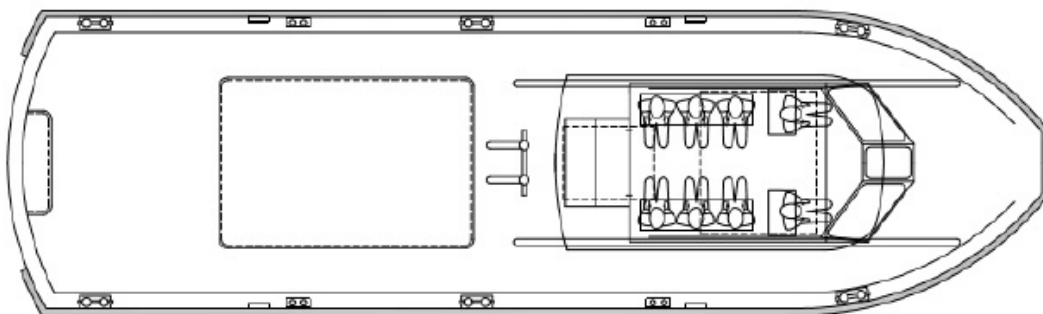
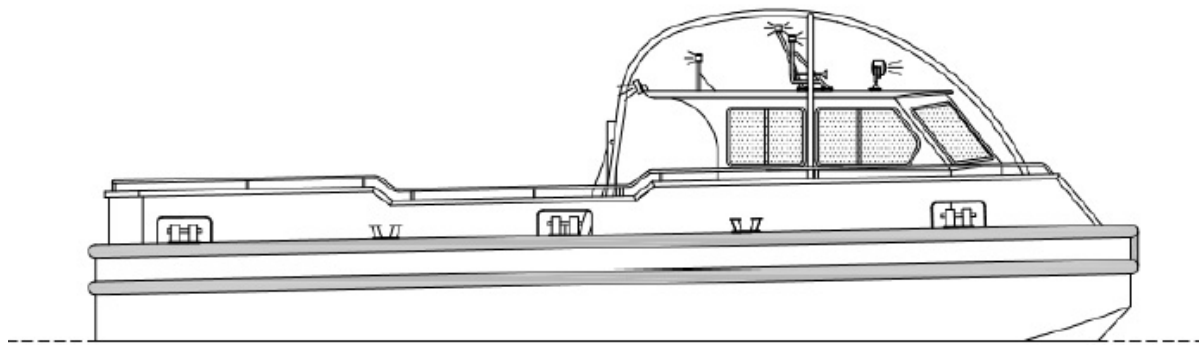

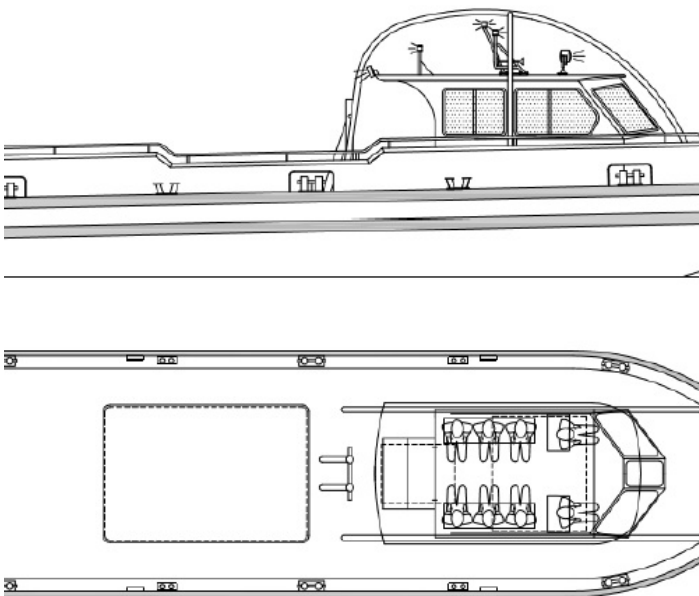

The details of all vessels are offered in good faith but we cannot guarantee or warrant the accuracy of this information nor warrant the condition of the vessel. Any buyer should instruct their agents, or their surveyors, to investigate such details as the buyer desires validated. This vessel is offered subject to sale, price change, location or withdrawal without notice.

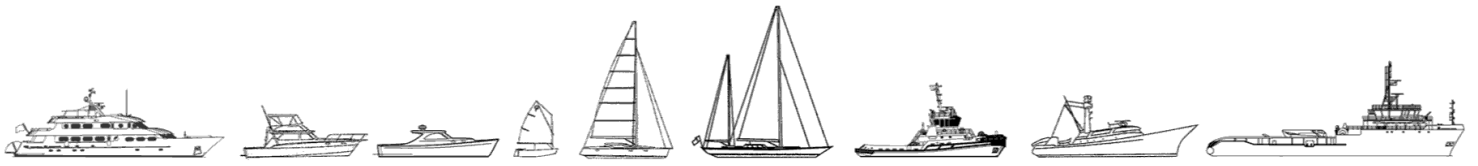

AUSTRALIA - BULGARIA - INDIA - INDONESIA - ITALY - MALAYSIA - NEW ZEALAND - PANAMA - PHILIPPINES - SINGAPORE - SPAIN - UK - USA - VENEZUELA - VIETNAM